

*Fresno-
Clovis*

CLASS 

BIKEWAY
DESIGN
GUIDE

2017



Table of Contents

CHAPTER 1

CONTEXT	5
Introduction.....	6
Guidance Basis	8
Bicycle User Types	10
Facility Selection.....	11
Design Needs of Bicyclists	14

CHAPTER 2

CLASS IV SEPARATED BIKEWAY TYPICAL CROSS SECTIONS	17
Introduction.....	18
50 Foot Roadways	19
60 Foot Roadways.....	20
64 Foot Roadways	21
74 Foot Roadways.....	22

CHAPTER 3

CLASS IV SEPARATED BIKEWAYS	23
One-way Separated Bikeways.....	24
Two-Way Separated Bikeways.....	26
Mixing Zone	28
Lateral Shift	30
Protected Intersection.....	32
Separated Bikeway Signal Phase.....	34
Leading Bicycle Interval	36
Two-Stage Turn Box.....	38
Separated Bikeway Barriers.....	40
Separated Bikeways at Driveways (and Minor Streets).....	42
Loading/Garbage Access.....	44
Facility Maintenance.....	46



Chapter 1

Context

Introduction

Class IV Bikeways are on-street bicycle facilities that include a vertical physical barrier between the bikeway and moving traffic, such as flexible bollards, a raised curb, on-street parking, or planter boxes. Depending on the agency or jurisdiction, separated bikeways may also be referred to as “protected bikeways” or “cycle tracks,” or “separated or protected bike lanes.” In California, the preferred term is “separated bikeway.”

They are not designated as bike lanes in California because of a statutory requirement that bicyclists must ride in a bike lane when one is present. As such, bicyclists are not obligated to use separated bikeways and may choose to ride with traffic instead.

Class IV Bikeways can be designed to allow for either one- or two-way travel. Two-way travel can be considered a special treatment that is only recommended with specific roadway characteristics and conditions. As a result, this guide focuses on one-way travel Class IV Bikeways which are easier to implement, and are more intuitive for all road users.

PRIORITIZING CORRIDORS FOR CONNECTIVITY

Separated bikeways should be prioritized along corridors that offer the greatest connectivity benefits for bicyclists. By providing safer and more comfortable bicycling facilities along high-speed or high-volume corridors, separated bikeways can link low-stress portions of a community’s street grid or close a gap between existing bikeways. Because bicyclists exert effort as they travel, most people are only willing to detour a short distance to reach a comfortable bicycle facility. Investing in high-quality bikeways at strategic locations can open up bicycling as a viable choice for many more residents. Routes should balance the needs of bicyclists making short local trips in addition to creating regional connections.





Street Level Separated Bikeways can be separated from the street with parking, planters, bollards or other design elements.



A clearly delineated buffer area provides sufficient space between the bicyclists' path of travel and the door zone of the adjacent parking lane.

UTILIZING THE GRID

Bikeway networks in urban areas can be disrupted by high-speed, high-volume streets that feel unsafe or uncomfortable for bicyclists in conventional bike lanes. Separated bikeways can increase network density by allowing comfortable bicycle facilities to be provided on these high-stress roadways through traffic calming measures such as road diets or lane width reductions.

Only a small percentage of the population is likely to be comfortable bicycling near traffic in a standard bicycle lane, making low-stress bicycle networks critical to increasing bicycling. Separated bikeways can close key gaps or provide connectivity along corridors that would otherwise be unusable for most bicyclists.

On high-speed roadways where separated bikeways are not possible due to insufficient roadway widths, frequent driveways, or other geometric constraints, the broader grid network of roadways offers alternative parallel streets for Class IV bikeways, with minor out-of-direction travel.

GOOD, BETTER, BEST PRACTICES

Separated bikeways provide increased safety and comfort for bicyclists beyond more traditional facilities like bicycle routes or bicycle lanes. While these minimal treatments may be sufficient to support bicycling on streets with relatively low traffic speeds and volumes, increased operating space and physical separation can further increase bicyclist comfort levels and therefore expand the street network accessible to most bicyclists.

Separation types range from simple painted buffers and flexible delineators, to more substantial separation measures including raised curbs, grade separation, bollards, planters, and parking lanes. These options range in feasibility due to roadway characteristics, available space, and cost. In some cases, it may be possible to provide additional space in areas where pedestrian and bicyclists may interact, such as the parking buffer, or loading zones, or extra bike lane width for cyclists to pass one another.

Corridor characteristics that should be taken into account when selecting the type of bikeway include traffic speeds and volumes, heavy vehicle volumes, on-street parking, intersection and driveway density, and surrounding land uses. This guide provides a starting point to identify minimum and preferred bikeway types for various vehicle speeds, traffic volumes, and roadway types.

Guidance Basis

The sections that follow serve as an inventory of pedestrian and bicycle design treatments and provide guidelines for their development. These treatments and design guidelines are important because they represent the tools for creating a walking- and bicycle-friendly, safe, accessible community. The guidelines are not, however, a substitute for a more thorough evaluation by a professional upon implementation of facility improvements. The following standards and guidelines are referred to in this guide.

NATIONAL GUIDANCE



IMPACT ON SAFETY AND CRASHES

*Walking and biking facilities can have a significant influence on user safety. The Federal Highway Administration's (FHWA) **Crash Modification Factor Clearinghouse** (<http://www.cmfclearinghouse.org/>) is a web-based database of Crash Modification Factors (CMF) to help transportation engineers identify the most appropriate countermeasure for their safety needs. Where available and appropriate, CMFs or similar study results are included for each treatment.*

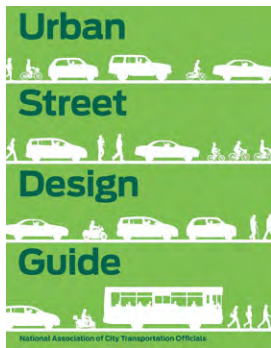

*The National Association of City Transportation Officials' (NACTO) **Urban Bikeway Design Guide (2012)** and **Urban Street Design Guide (2013)** are collections of nationally recognized street design standards, and offers guidance on the current state of the practice designs.*



***Separated Bike Lane Planning and Design Guide (2015)** is the latest national guidance on the planning and design of separated bike lane facilities released by the Federal Highway Administration (FHWA). The resource documents best practices as demonstrated around the U.S., and offers ideas on future areas of research, evaluation and design flexibility.*

CALIFORNIA GUIDANCE



The California Manual on Uniform Traffic Control Devices (CAMUTCD) (2014) is an amended version of the FHWA MUTCD 2009 edition modified for use in California. While standards presented in the CA MUTCD substantially conform to the FHWA MUTCD, the state of California follows local practices, laws and requirements with regards to signing, striping and other traffic control devices.



Main Street, California: A Guide for Improving Community and Transportation Vitality (2013) reflects California's current manuals and policies that improve multimodal access, livability and sustainability within the transportation system. The guide recognizes the overlapping and sometimes competing needs of main streets.



The California Highway Design Manual (HDM) (Updated 2015) establishes uniform policies and procedures to carry out highway design functions for the California Department of Transportation.



The Caltrans Memo: Design Flexibility in Multimodal Design (2014) encourages flexibility in highway design. The memo stated that "Publications such as the National Association of City Transportation Officials (NACTO) "Urban Street Design Guide" and "Urban Bikeway Design Guide," ... are resources that Caltrans and local entities can reference when making planning and design decisions on the State highway system and local streets and roads."

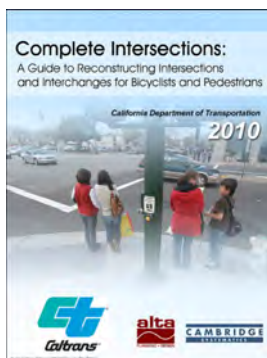

Complete Intersections: A Guide to Reconstructing Intersections and Interchanges for Bicyclists and Pedestrians (2010) is a reference guide that presents information and concepts related to improving conditions for bicyclists and pedestrians at major intersections and interchanges. The guide can be used to inform minor signage and striping changes to intersections, as well as major changes and designs for new intersections.

Bicycle User Type

The current AASHTO Guide to the Development of Bicycle Facilities encourages designers to identify their rider type based on the trip purpose (Recreational vs Transportation) and on the level of comfort and skill of the rider (Causal vs Experienced). A user-type framework for understanding a potential rider’s willingness to bike is illustrated in the figure below. Developed by planners in Portland, OR* and supported by research**, this classification identifies four distinct types of bicyclists.

Strong and Fearless - This group is willing to ride a bicycle on any roadway regardless of traffic conditions. They are comfortable taking the lane and riding in a vehicular manner on major streets without designated bicycle facilities.

Enthusied and Confident - This group of bicyclists is willing to ride in most roadway situations but prefers to have a designated facility. They are comfortable riding on major streets with a bike lane.

Interested but Concerned - This group is more cautious and has some inclination towards bicycling, but is held back by concern over sharing the road with cars. They are not very comfortable on major streets, even with a striped bike lane, and prefer separated pathways or low traffic neighborhood streets.

No Way, No How - This group comprises residents who simply aren’t interested at all in bicycling and may be physically unable or don’t know how to ride a bicycle, and they are unlikely to adopt bicycling in any way.

Typical Distribution of Bicyclist Types

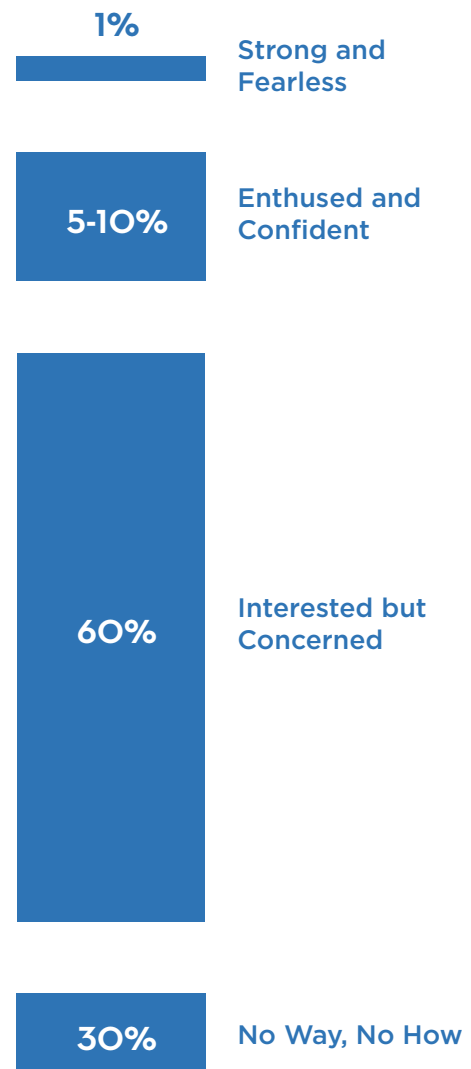

* Roger Geller, City of Portland Bureau of Transportation. Four Types of Cyclists. <http://www.portlandonline.com/transportation/index.cfm?&a=237507>. 2009.

** Dill, J., McNeil, N. Four Types of Cyclists? Testing a Typology to Better Understand Bicycling Behavior and Potential. 2012.

Facility Selection

In order to provide a bikeway network that meets the needs of the Fresno-Clovis Metro’s “Interested but Concerned” residents (who comprise the majority of the population), bikeways must be low-stress and comfortable. By using a metric called Level of Traffic Stress (LTS), specific facility types can be matched to the needs of people who bicycle in Fresno-Clovis Metro Area. Generally, “Interested but Concerned,” users will only bicycle on LTS 1 or LTS 2 facilities.

Levels of Traffic Stress (LTS)

LTS LEVEL	DESCRIPTION	WHAT TYPE OF BICYCLISTS WILL RIDE ON THIS LTS FACILITY?		
		STRONG & FEARLESS	ENTHUSIASTIC & CONFIDENT	INTERESTED BUT CONCERNED
LTS 1	Presents the lowest level of traffic stress; demands less attention from people riding bicycles, and attractive enough for a relaxing bicycle ride. Suitable for almost all people riding bicycles, including children trained to ride in the street and to safely cross intersections.	YES	YES	YES
LTS 2	Presents little traffic stress and therefore suitable to most adults riding bicycles, but demands more attention than might be expected from children.	YES	YES	SOMETIMES
LTS 3	More traffic stress than LTS2, yet significantly less than the stress of integrating with multilane traffic.	YES	SOMETIMES	NO
LTS 4	A level of stress beyond LTS 3. Includes roadways that have no dedicated bicycle facilities and moderate to higher vehicle speeds and volumes OR high speed and high volume roadways WITH an exclusive riding zone (lane) where there is a significant speed differential with vehicles.	YES	NO	NO

Facility Selection (Continued)

Selecting the best bikeway facility type for a given roadway can be challenging, due to the range of factors that influence bicycle users' comfort and safety. There is a significant impact on cycling comfort when the speed differential between bicyclists and motor vehicle traffic is high and motor vehicle traffic volumes are high. This page can help determine when a Class IV Bikeway is most appropriate relative to other facility types.

FACILITY SELECTION TABLE

As a starting point to identify a preferred facility, the chart below can be used to determine the recommended type of bikeway to be provided in particular roadway speed and volume situations. To use this chart, identify the appropriate daily traffic volume on the existing or proposed roadway, and locate the facility types indicated by those key variables.

Other factors beyond volume which affect facility selection include traffic speed, traffic mix of automobiles and heavy vehicles, the presence of on-street parking, intersection density, surrounding land use, and roadway sight distance. These factors are not included in the facility selection chart below, but should always be considered in the facility selection and design process.

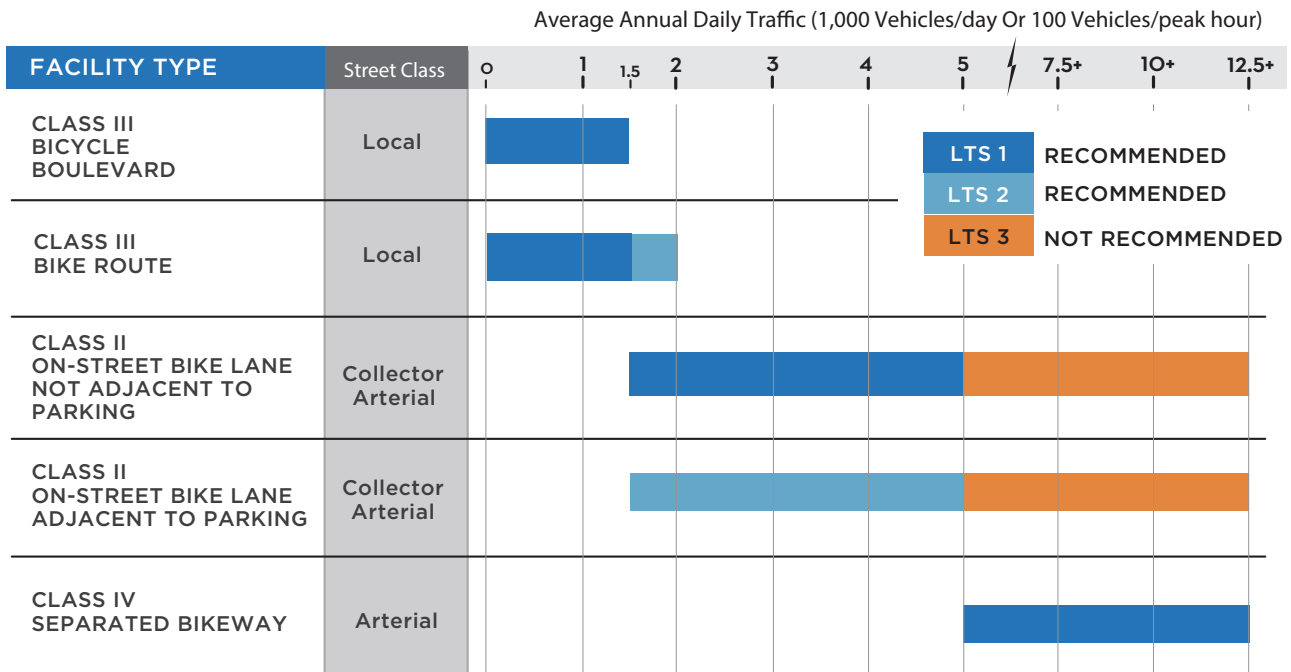

(Average Daily Vehicles, per 1,000)

This page left blank intentionally

Design Needs of Bicyclists

The facility designer must have an understanding of how bicyclists operate and how their bicycle influences that operation. Bicyclists, by nature, are much more affected by poor facility design, construction and maintenance practices than motor vehicle drivers.

By understanding the unique characteristics and needs of bicyclists, a facility designer can provide quality facilities and minimize user risk.

BICYCLE AS A DESIGN VEHICLE

Similar to motor vehicles, bicyclists and their bicycles exist in a variety of sizes and configurations. These variations occur in the types of vehicle (such as a conventional bicycle, a recumbent bicycle or a tricycle), and behavioral characteristics (such as the comfort level of the bicyclist). The design of a bikeway should consider reasonably expected bicycle types on the facility and utilize the appropriate dimensions.

The figure to the right illustrates the operating space and physical dimensions of a typical adult bicyclist, which are the basis for typical facility design. Bicyclists require clear space to operate within a facility. This is why the minimum operating width is greater than the physical dimensions of the bicyclist. Bicyclists prefer five feet or more operating width. The minimum width for a bicycle lane in Fresno is five feet, not including the gutter pan.

In addition to the design dimensions of a typical bicycle, there are many other commonly used pedal-driven cycles and accessories to consider when planning and designing bicycle facilities. The most common types include tandem bicycles, recumbent bicycles, and trailer accessories. The figure to the left summarizes the typical dimensions for bicycle types.

Bicycle Rider - Typical Dimensions

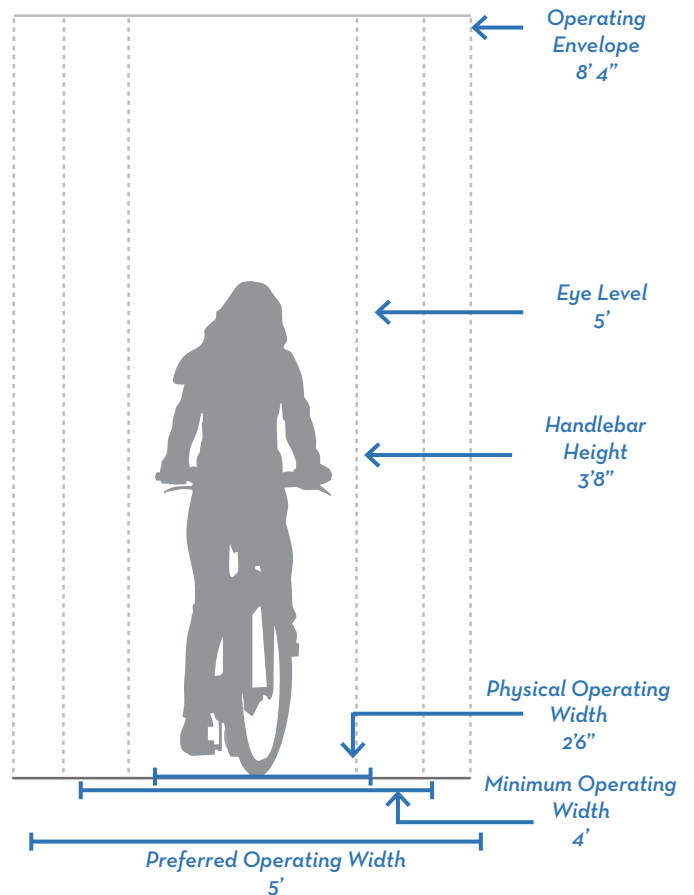

Bicycle Design Vehicle - Typical Dimensions

- A: Adult Typical Bicycle
- B: Adult Tandem Bicycle
- C: Adult Recumbent Bicycle
- D: Child Trailer Length
- E: Child Trailer Width
- F: Trailer Bike Length

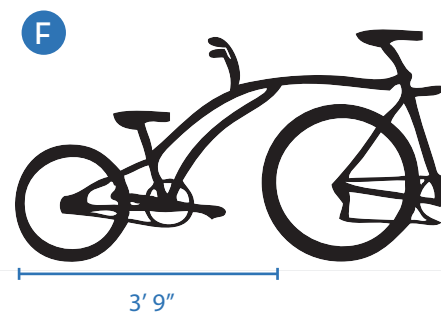
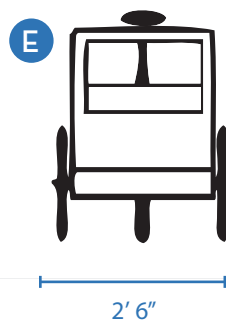
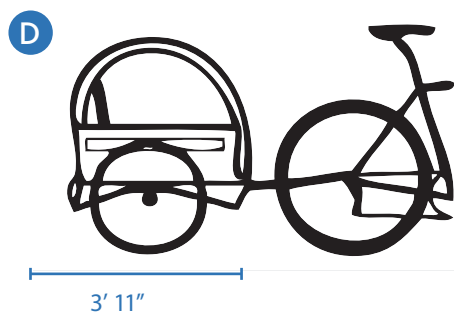
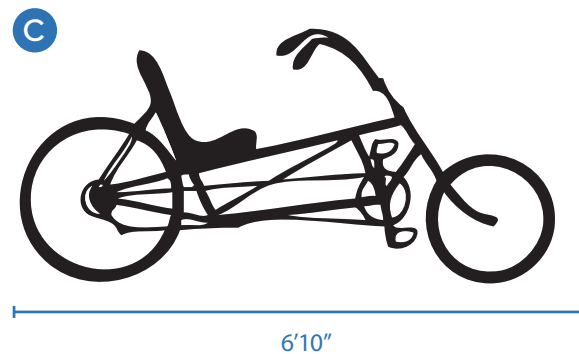
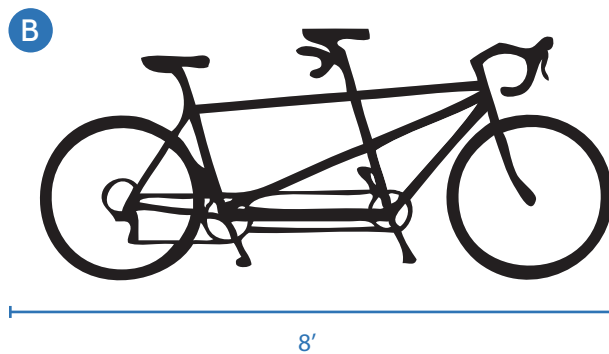
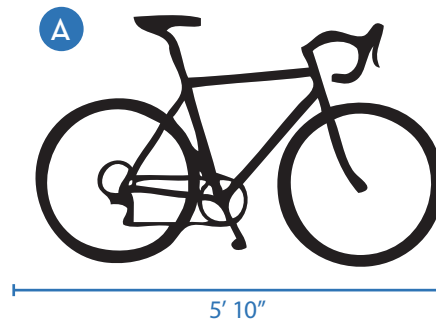

Source: AASHTO *Guide for the Development of Bicycle Facilities*, 4th Edition

Bicycle as Design Vehicle - Design Speed Expectations

BICYCLE TYPE	FEATURE	TYPICAL SPEED
Upright Adult Bicyclist	Paved level surfacing	8-12 mph*
	Crossing Intersections	10 mph
	Downhill	30 mph
	Uphill	5 -12 mph
Recumbent Bicyclist	Paved level surfacing	18 mph

* Typical speed for casual riders per AASHTO 2013.

Chapter II

CLASS 
SEPARATED
BIKEWAY
TYPICAL
CROSS
SECTIONS

CROSS-SECTION PROTOTYPES

Cross-section prototypes have been illustrated below to demonstrate how Class IV separated bikeways could be retrofitted to existing streets or developed for new roadways in Fresno and Clovis. These prototypes match lane dimensions and parking configurations characteristic to three and five lane roads in the Fresno-Clovis region. Parking and travel lanes can be preserved in many scenarios by simply narrowing travel lanes and swapping the position of the travel lane with a 3 foot minimum buffer and five foot minimum bikeway in accordance with Caltrans Design Information Bulletin 89. The Cities of Fresno and Clovis are not limited to the prototypes included here and should consult the FHWA Separated Bike Lane Planning and Design Guide, NACTO Urban Bikeway Design Guide, and Caltrans DIB 89 for additional design guidance.

While two-way separated bikeways may be feasible in some locations, public and stakeholder opinion strongly favored the one-way configuration illustrated here. One-way bikeways are typically less expensive to install, however, may require specialized street sweeping equipment. These costs are detailed in the Fresno-Clovis Class IV Feasibility Study.

ADDITIONAL RESOURCES

National Association of City Transportation Officials (NACTO) *Urban Bikeway Design Guide*

<http://nacto.org/publication/urban-bikeway-design-guide/cycle-tracks/one-way-protected-cycle-tracks/>

Federal Highways Administration (FHWA) *Separated Bike Lane Planning and Design Guide*

https://www.fhwa.dot.gov/environment/bicycle_pedestrian/publications/separated_bikelane_pdg/

Caltrans *Design Information Bulletin 89: Class IV Bikeway Guidance*

<http://www.dot.ca.gov/hq/oppd/dib/dib89.pdf>

50 Foot Roadways

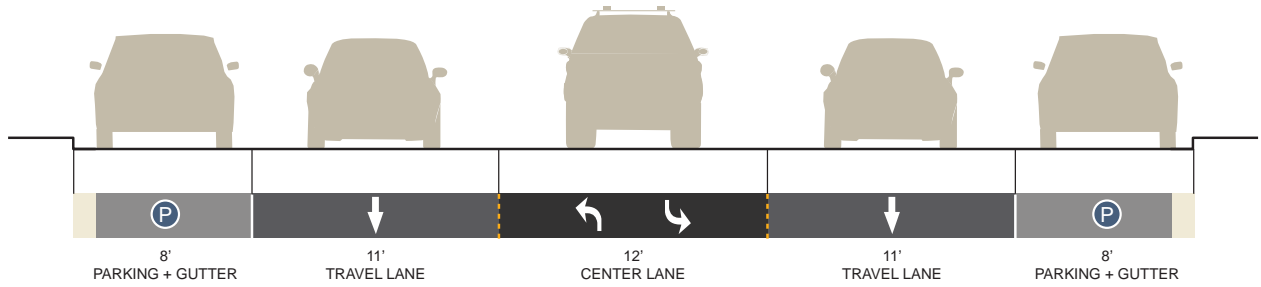

EXISTING

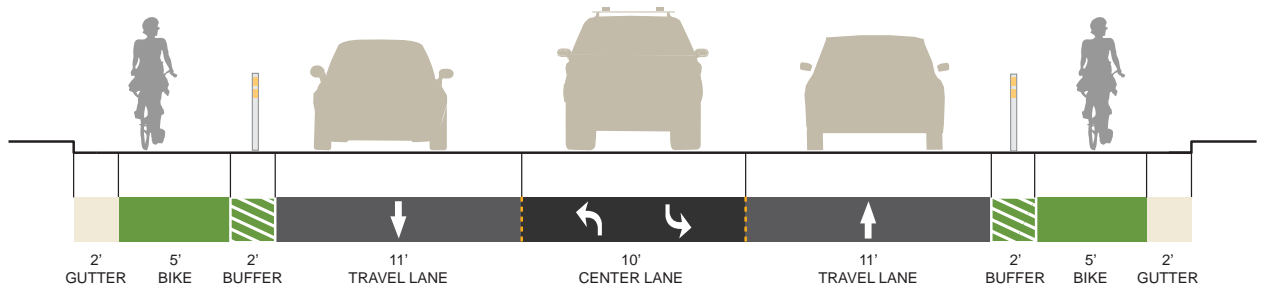

PROPOSED - NO PARKING

60 Foot Roadways

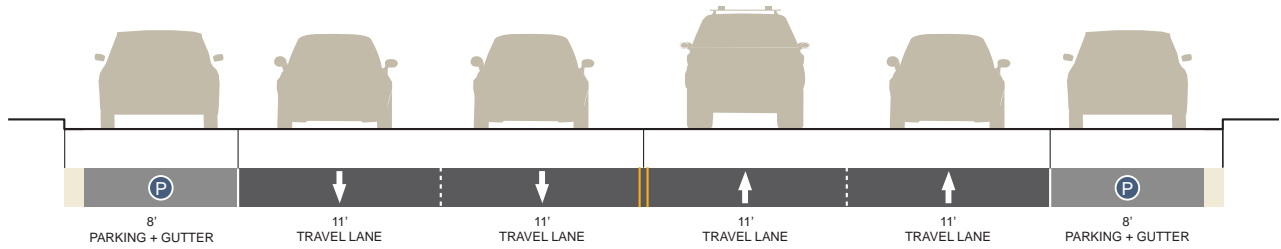

EXISTING

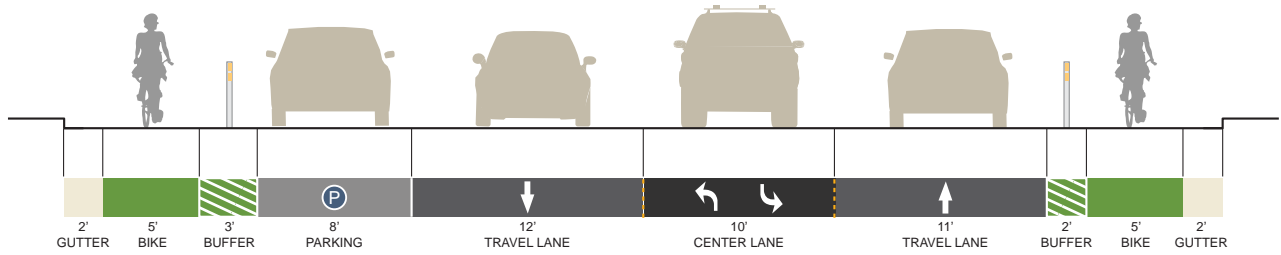

PROPOSED - PARKING ONE SIDE

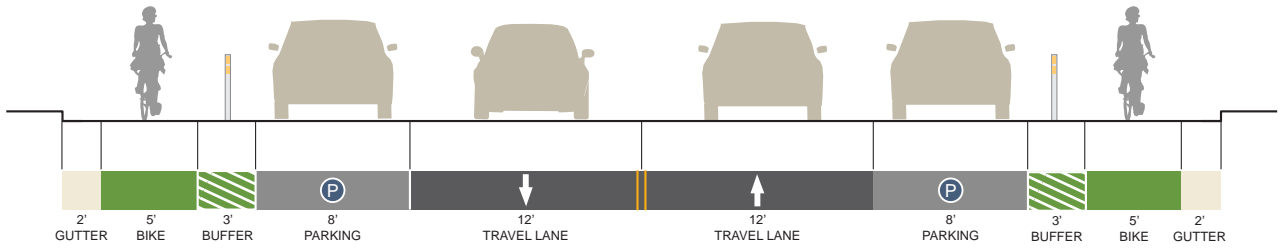

PROPOSED - PARKING ON TWO SIDES

64 Foot Roadways

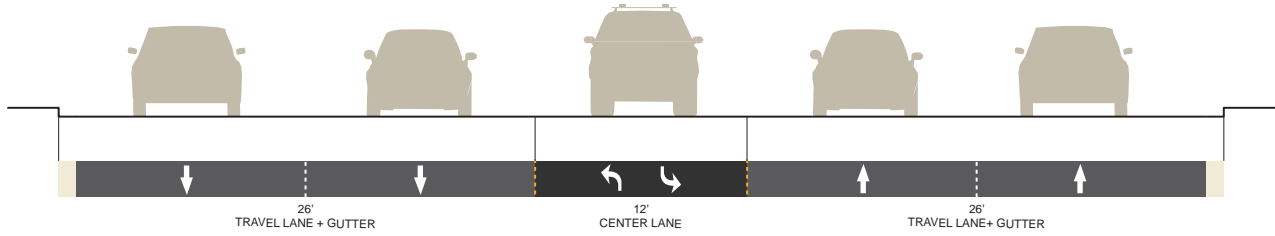

EXISTING

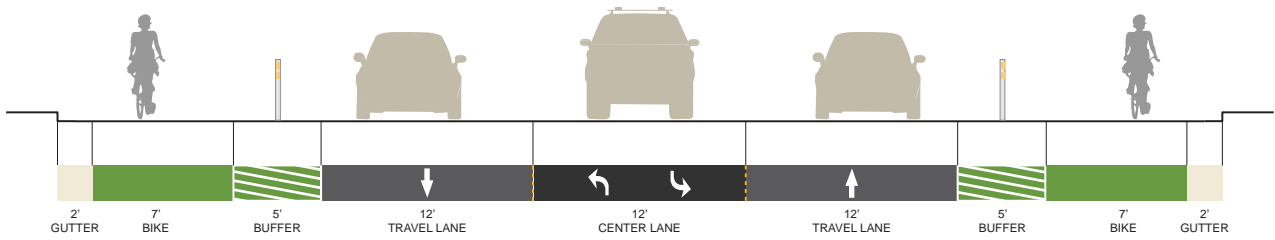

PROPOSED - NO PARKING

74 Foot Roadways

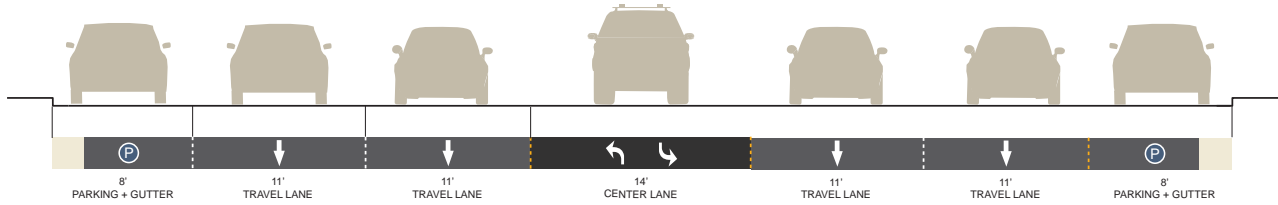

EXISTING

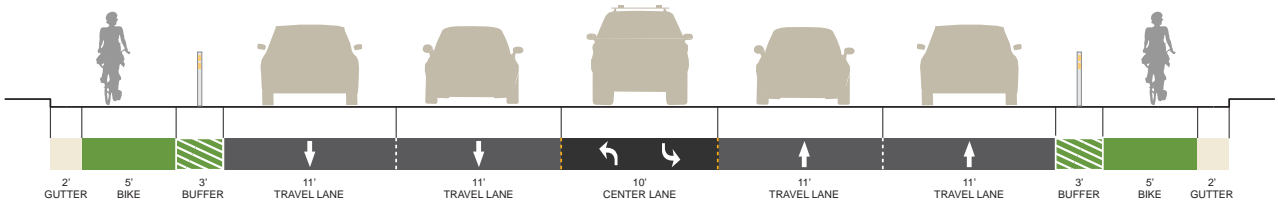

PROPOSED - NO PARKING

Chapter III

CLASS 
SEPARATED
BIKEWAYS

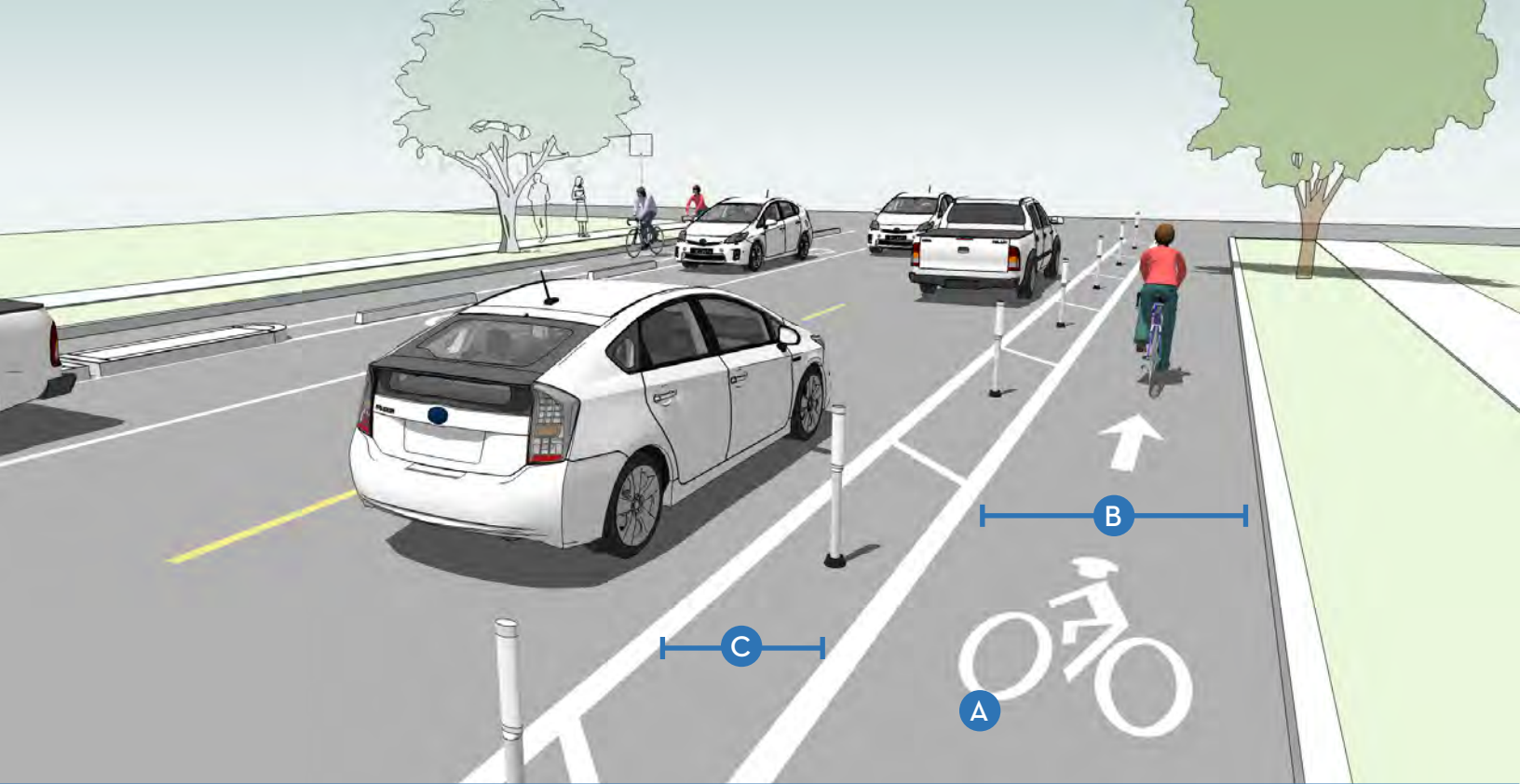

One-Way Separated Bikeway

 INTERSECTION
 MID-BLOCK

One-way separated bikeways are on-street bikeway facilities that are separated from vehicle traffic. Physical separation is provided by a barrier between the bike lane and the vehicular travel lane. These barriers can include flexible posts, bollards, parking, planter strips, extruded curbs, or on-street parking. Separated bikeways using these barrier elements typically share the same elevation as adjacent travel lanes, but the bikeway could also be raised above street level, either below or equivalent to sidewalk level.

TYPICAL APPLICATION

- Along streets on which conventional bicycle lanes would cause many bicyclists to feel stress because of factors such as multiple lanes, high bicycle volumes, high motor traffic volumes (9,000-30,000 ADT), higher traffic speeds (25+ mph), high incidence of double parking, higher truck traffic (10% of total ADT) and high parking turnover.
- Along streets for which conflicts at intersections can be effectively mitigated using parking lane setbacks, bicycle markings through the intersection, and other signalized intersection treatments.

DESIGN FEATURES

- A** Pavement markings, symbols and/or arrow markings must be placed at the beginning of the separated bike lane and at intervals along the facility based on engineering judgment to define the bike direction. (CAMUTCD 9C.04)
- B** 7 foot width preferred in areas with high bicycle volumes or uphill sections to facilitate safe passing behavior (5 foot minimum). (HDM 1003.1(1))
- C** 3 foot minimum buffer width adjacent to parking lines (2 foot minimum when adjacent to travel lanes), marked with 2 solid white (DIB 89, 2015).

Street Level Separated Bikeway



Parked cars in the image above serve as a barrier between bicyclists and the vehicle lane. Barriers could also include flexible posts, bollards, planters, or other design elements.

FURTHER CONSIDERATIONS

- Separated bikeway buffers and barriers are covered in the CAMUTCD as preferential lane markings (section 3D.01) and channelizing devices (section 3H.01). If the buffer area is 4 feet or wider, white chevron or diagonal markings should be used (section 9C.04). Curbs may be used as a channeling device, see the section on islands (section 3I.01). Grade-separation provides an enhanced level of separation in addition to buffers and other barrier types.
- Where possible, physical barriers such as removable curbs should be oriented towards the inside edge of the buffer to provide as much extra width as possible for bicycle use.
- A retrofit separated bikeway has a relatively low implementation cost compared to road reconstruction by making use of existing pavement and drainage and using a parking lane as a barrier.
- Gutters, drainage outlets and utility covers should be designed and configured as not to impact bicycle travel.
- For clarity at major or minor street crossings, consider a dotted line (CA MUTCD Detail 39A - Bike Lane Intersection Line) for the buffer boundary where cars are expected to cross.
- Special consideration should be given at transit stops to manage bicycle & pedestrian interactions.

CRASH REDUCTION

A before and after study in Montreal of separated bikeways shows that this type of facility can result in a crash reduction of 74% for collisions between bicyclists and vehicles. (CMF ID: 4097) In this study, there was a parking buffer between the bike facility and vehicle travel lanes. Other studies have found a range in crash reductions due to SBL, from 8% (CMF ID: 4094) to 94% (CMF ID: 4101).

CONSTRUCTION COSTS

The implementation cost is low if the project uses existing pavement and drainage, but the cost significantly increases if curb lines need to be moved, as in the case of a grade-separated facility. A parking lane is the low-cost option for providing a barrier. Other barriers might include concrete medians, bollards, tubular markers, or planters.

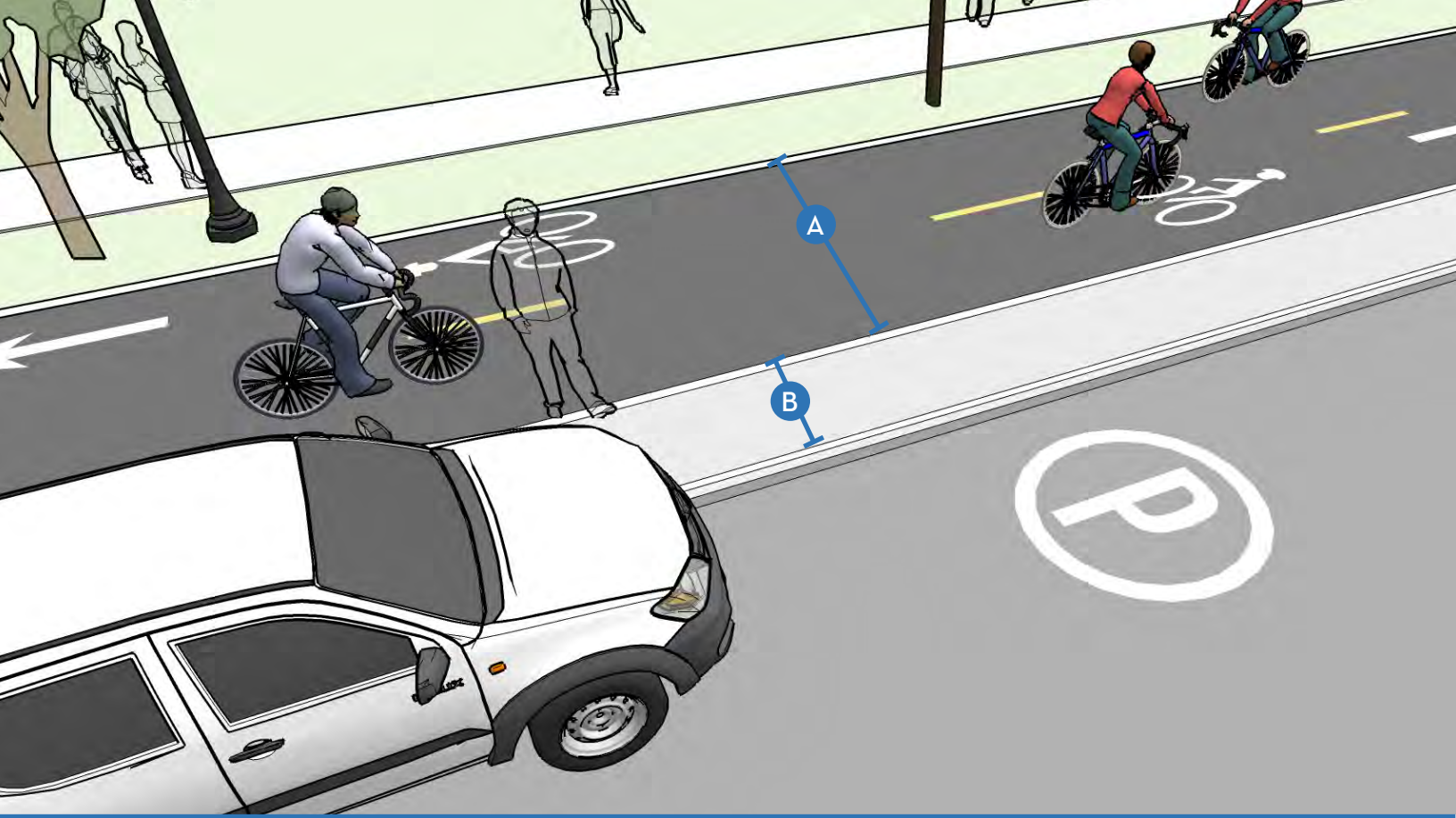

Two-Way Separated Bikeway



Two-Way Separated Bikeways are bicycle facilities that allow bicycle movement in both directions on one side of the road. Two-way separated bikeways share some of the same design characteristics as one-way separated bikeways, but often require additional considerations at driveway and side-street crossings, and intersections with other bikeways.

TYPICAL APPLICATION

- Works best on the left side of one-way streets.
- Streets with high motor vehicle volumes and/or speeds
- Streets with high bicycle volumes.
- Streets with a high incidence of wrong-way bicycle riding.
- Streets with few conflicts such as driveways or cross-streets on one side of the street.
- Streets that connect to shared use paths.

DESIGN FEATURES

- A** 12 foot operating width preferred (10 ft minimum) width for two-way facility.
- In constrained locations an 8 foot minimum operating width may be considered. **(HDM 1003.1(1))**
- B** Adjacent to on-street parking a 3 foot minimum width channelized buffer or island shall be provided to accommodate opening doors. **(NACTO, 2012) (CAMUTCD 3H.01, 3I.01)**
- A separation narrower than 5 feet may be permitted if a physical barrier is present. **(AASHTO, 2013)**
- Additional signalization and signs may be necessary to manage conflicts.

Two-Way Separated Bikeway



A two-way facility can accommodate cyclists in two directions of travel.

FURTHER CONSIDERATIONS

- On-street bike lane buffers and barriers are covered in the CAMUTCD as preferential lane markings (section 3D.01) and channelizing devices, including flexible delineators (section 3H.01). Curbs may be used as a channeling device, see the section on islands (section 3I.01).
- A two-way separated bikeway on one way street should be located on the left side.
- A two-way separated bikeway may be configured at street level or as a raised separated bicycle lane with vertical separation from the adjacent travel lane.
- Two-way separated bikeways should ideally be placed along streets with long blocks and few driveways or mid-block access points for motor vehicles.
- See Caltrans Design Information Bulletin No. 89 for more details.

CRASH REDUCTION

A study of bicyclists in two-way separated facilities found that accident probability decreased by 45% at intersections where the separated facility approach was detected between 6.5 and 16.4 feet (2-5 meters) from the side of the main road and when bicyclists had crossing priority at intersections. (CMF ID: 3034) Installation of a two-way separated bike lane 0-6.5 feet (0-2 meters) from the side of the main road resulted in an increase in collisions at intersections by 3% (CMF ID: 4033).

CONSTRUCTION COSTS

The implementation cost is low if the project uses existing pavement and drainage, but the cost significantly increases if curb lines need to be moved. A parking lane is the low-cost option for providing a barrier. Other barriers might include concrete medians, bollards, tubular markers, or planters.

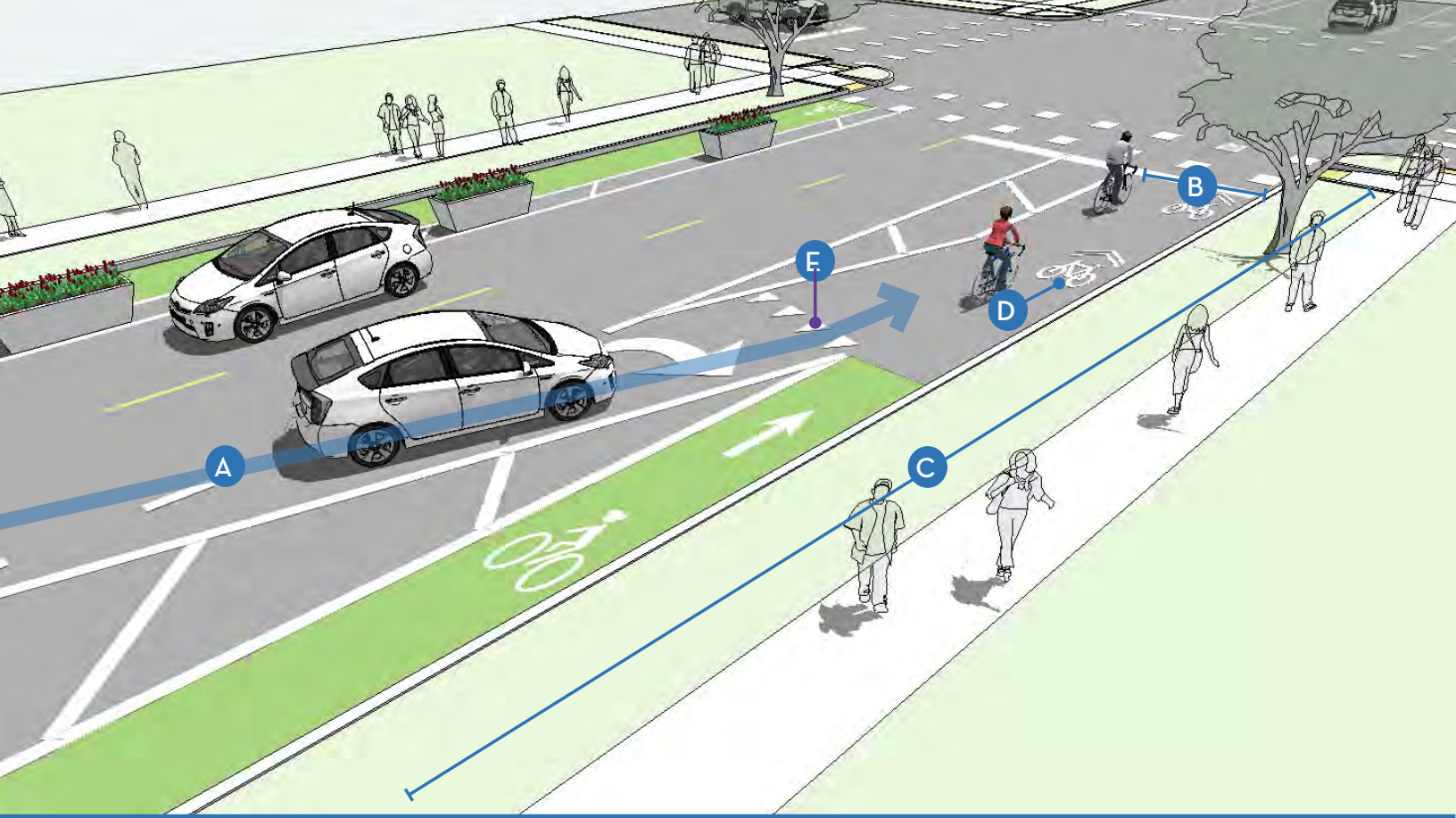

Mixing Zone



A mixing zone creates a shared travel lane where turning motor vehicles yield to through traveling bicyclists. Geometric design is intended to slow motor vehicles to bicycle speed, provide regulatory guidance to people driving, and require all users to negotiate conflicts upstream of the intersection.

TYPICAL APPLICATION

- Most appropriate in areas with low to moderate right-turn volumes
- Streets with a right turn lane but not enough width to have a standard width bicycle lane at the intersection.

DESIGN FEATURES

- A** Use short transition taper dimensions and short storage length to promote slow motor vehicle travel speeds.
- B** The width of the mixing zone should be 9 feet minimum and 13 feet maximum.
- C** The transition to the mixing zone should begin 70 feet in advance of the intersection.
- D** Shared lane markings (CAMUTCD 9C-9) should be used to illustrate the bicyclist's position within the lane.
- E** A yield line should be used in advance of the intersection.

Mixing Zone (New York City, NY)



Mixing zone (Photo via NACTO)

FURTHER CONSIDERATIONS

- Not recommended at intersections with high peak motor vehicle right turn movements.
- The zone creates safety and comfort benefits by having the mixing zone upstream of the intersection conflict area.

CRASH REDUCTION

A survey of separated bike lane users in the United States found that 60-80% of respondents agreed with the statement “I generally feel safe when bicycling through the intersections” when asked about intersections with mixing zone approaches.¹

CONSTRUCTION COSTS

The cost for installing a mixing zone will depend on the implementation approach. On roadways with adequate width for reconfiguration or restriping, costs may be negligible when provided as part of routine overlay or repaving projects.

Typical costs are \$16,000 per mile for restriping. Typical yield lines cost \$10 per square foot or \$320 each. Typical shared lane markings cost \$180 each.

¹ NITC. Lessons from the Green Lanes. 2014.

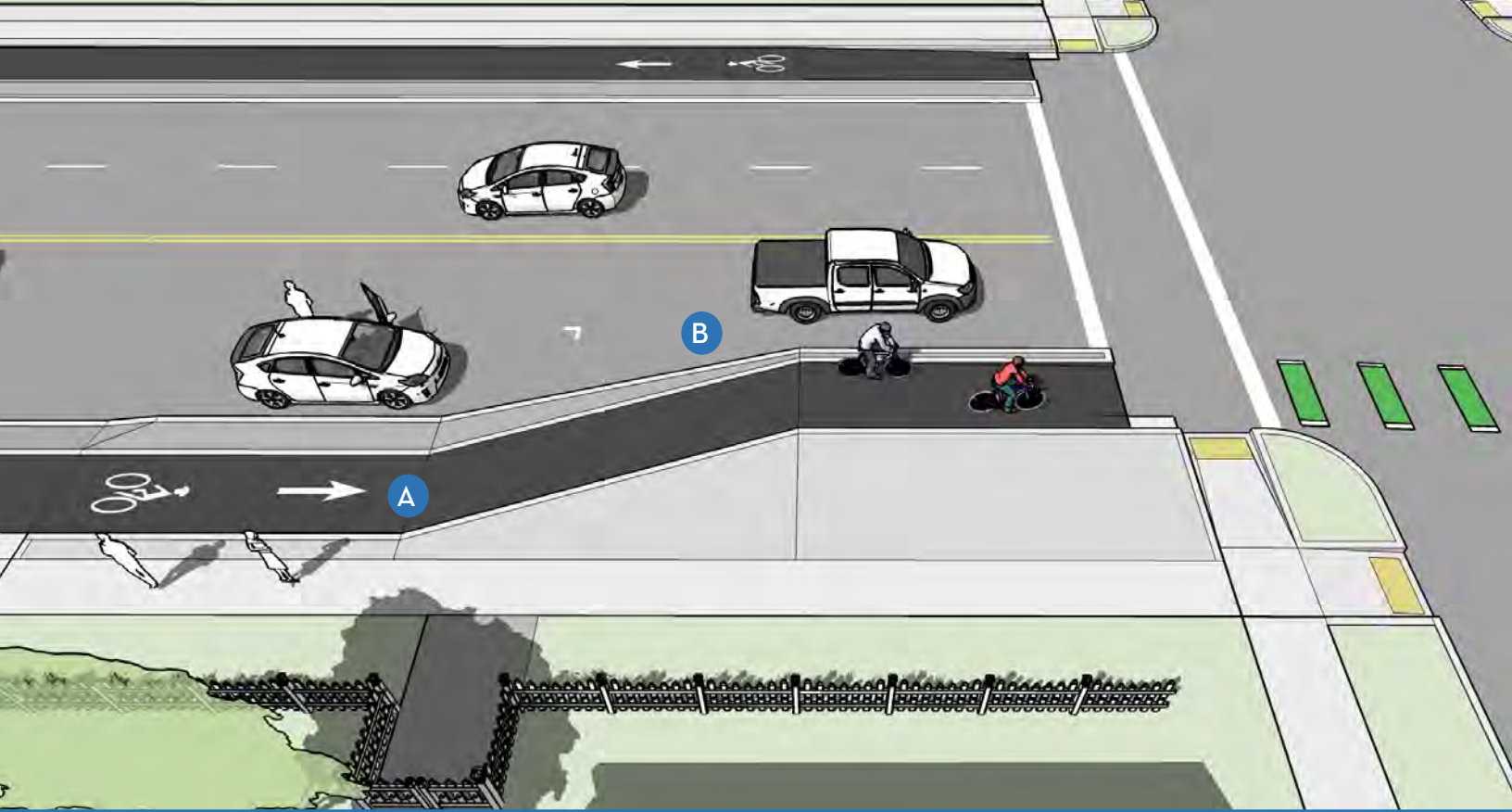

Lateral Shift



To increase the visibility of bicyclists for turning motorists, a lateral shift in or “bend-in” intersection approach laterally shifts the separated bikeway immediately adjacent to the turning lane.

TYPICAL APPLICATION

- Where bikeways are separated by a visually intensive buffer or on-street parking.
- Where it is desirable to create a curb extension at intersections to reduce pedestrian crossing distance.
- Where space is not available to bend-out the bikeway prior to the intersection.

DESIGN FEATURES

- A** At least 20 ft prior to an intersection, provide between 20 - 40 ft of length to shift the bikeway closer to motor vehicle traffic.
- B** Where the separated bikeway uses parked cars within the buffer zone, parking must be prohibited at the start of the transition.
- Place a “Turning Vehicles Yield to Bikes” sign (modified MUTCD R10-15) prior to the intersection.
- Optional - Provide a narrow buffer with vertical delineators between the travel lane and the bikeway to increase comfort for bicycle riders and slow driver turning speed.

Overcrossings



A bend-in intersection in Missoula, MT

Undercrossings



A bend-in intersection in Vancouver, BC

FURTHER CONSIDERATIONS

- The design creates an opportunity for a curb extension, to reduce pedestrian crossing distance. This curb extension can also create public space which can be used for bike parking corrals, bikeshare stations, parklets, public art exhibits, and/or stormwater features such as bioswales.
- Can be paired with intersection crossing markings, such as green colored pavement, to raise awareness of conflict points.

CRASH REDUCTION

Separated bikeways with “bend-in” approaches create geometry similar to that of conventional on-street bike lanes and should offer a similar safety performance to those designs.

CONSTRUCTION COSTS

The costs of bend-in intersections vary depending on materials used and degree of implementation desired. Inexpensive materials can be used, such as paint, concrete planters, and bollards.



Protected Intersection



A protected intersection, or “bend-out” uses a collection of intersection design elements to maximize user comfort within the intersection and promote a high rate of motorists yielding to people bicycling. The design maintains a physical separation within the intersection to define the turning paths of motor vehicles, slow vehicle turning speed, and offer a comfortable place for people bicycling to wait at a red signal.

TYPICAL APPLICATION

- Streets with separated bikeways protected by wide buffer or on-street parking.
- Where two separated bikeways intersect and two-stage left-turn movements can be provided for bicycle riders.
- Helps reduce conflicts between right-turning motorists and bicycle riders by reducing turning speeds and providing a forward stop bar for bicycles.
- Where it is desirable to create a curb extension at intersections to reduce pedestrian crossing distance.

DESIGN FEATURES

- A** Setback bicycle crossing of 16.5 feet allows for one passenger car to queue while yielding. Smaller setback distance is possible in slow-speed, space constrained conditions.
- B** Corner safety island with a 15-20 foot corner radius slows motor vehicle speeds. Larger radius designs may be possible when paired with a deeper setback or a protected signal phase, or small mountable aprons. Two-stage turning boxes are provided for queuing bicyclists adjacent to corner islands.
- C** Use intersection crossing markings.

Protected Intersection



Protected intersections feature a corner safety island and intersection crossing markings.



Protected intersections incorporate queuing areas for two-stage left turns.

FURTHER CONSIDERATIONS

- Pedestrian crosswalks may need to be further set back from intersections in order to make room for two-stage turning queue boxes.
- Wayfinding and directional signage should be provided to help bicycle riders navigate through the intersection.
- Colored pavement may be used within the corner refuge area to clarify use by people bicycling and discourage use by people walking or driving.
- Intersection approaches with high volumes of right turning vehicles should provide a dedicated right turn only lane paired with a protected signal phase. Protected signal phasing may allow different design dimensions than are described here.

CRASH REDUCTION

Studies of “bend-out” intersection approaches find that separation distance of 6.5 - 16.5 ft offer the greatest safety benefit, with a better safety record than conventional bike lane designs.¹

CONSTRUCTION COSTS

- Reconstruction costs comparable to a full intersection.
- Retrofit implementation may be possible at lower costs if existing curbs and drainage are maintained.

¹ Schepers et al. Road factors and Bicycle-Motor vehicle crashes at unsignalized priority intersections. 2011.

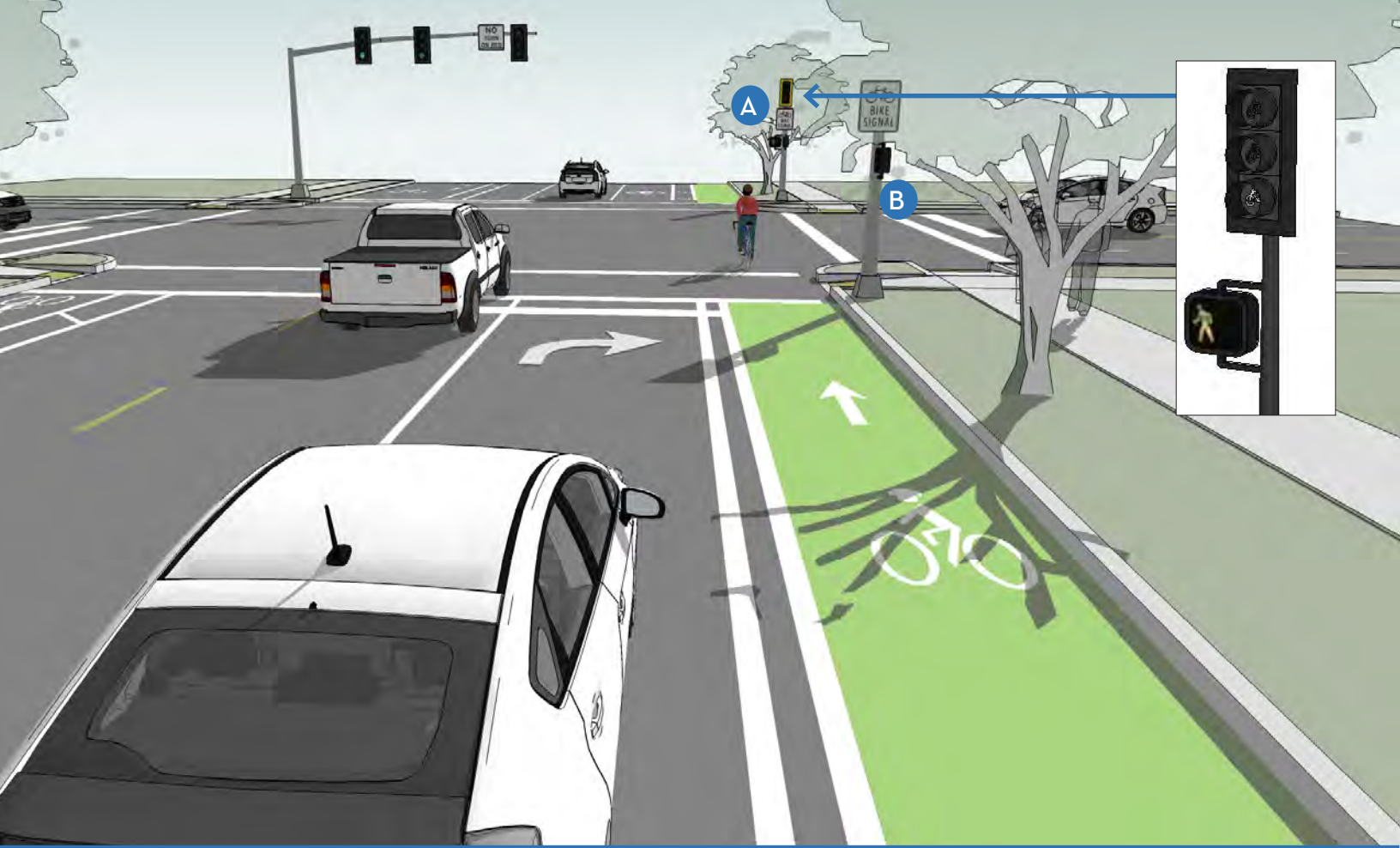

Separated Bikeway Signal Phase



Separated bikeway crossings of signalized intersections can be accomplished through the use of a bicycle signal phase which reduces conflicts with motor vehicles by separating bicycle movements from any conflicting motor vehicle movements. Bicycle signals are traditional three lens signal heads with green, yellow and red bicycle stenciled lenses.

TYPICAL APPLICATION

- Two-way separated bikeway where contraflow bicycle movement or increased conflict points warrant protected operation.
- Bicyclists moving on a green or yellow signal indication in a bicycle signal shall not be in conflict with any simultaneous motor vehicle movement at the signalized location
- Right turns on red (or left turns, on one-way streets) should be prohibited in locations where such operation would conflict with a green bicycle signal indication.

DESIGN FEATURES

- A** An additional “Bicycle Signal” sign should be installed below the bicycle signal head.
- B** Designs for bicycles at signalized crossings should allow bicyclists to trigger signals and safely maneuver the crossing.
- On bikeways, signal timing and actuation shall be reviewed and adjusted to consider the needs of bicyclists. **(CAMUTCD 9D.02)**

Protected Bicycle Signal Phase



A bicycle signal head at a signalized crossing creates a protected phase for cyclists to safely navigate an intersection.



A bicycle detection system triggers a change in the traffic signal when a bicycle is detected.

FURTHER CONSIDERATIONS

- A bicycle signal should be considered for use only when the volume/collision or volume/geometric warrants have been met. **(CAMUTCD 4C.102)**
- FHWA has approved bicycle signals for use, if they comply with requirements from FHWA Interim Approval for Optional Use of Bicycle Signal Faces (I.A. 16). Bicycle Signals are not approved for use in conjunction with Pedestrian Hybrid Beacons.
- Bicyclists typically need more time to travel through an intersection than motor vehicles. Green light times should be determined using the bicycle crossing time for standing bicycles.
- Bicycle detection and actuation systems include user-activated buttons mounted on a pole, loop detectors that trigger a change in the traffic signal when a bicycle is detected and video detection cameras, that use digital image processing to detect a change in the image at a location.

CRASH REDUCTION

A survey of separated bikeway users in the United States found the 92% of respondents agreed with the statement “I generally feel safe when bicycling through the intersections” when asked about an intersection with a protected bicycle signal phase.¹

CONSTRUCTION COSTS

Bicycle signal heads have an average cost of \$12,800.

Video detection camera system costs range from \$20,000 to \$25,000 per intersection.

1 NITC. Lessons from the Green Lanes. 2014.

Leading Bicycle Interval

Vehicle conflicts can occur when drivers performing turning movements do not see or yield to bicyclists who have the right-of-way. Bicyclists may also arrive at an intersection late, or may not have any indication of how much time they have to safely cross the intersection. Bicycle traffic signal enhancements can be made to provide bicyclists with a head start, called a Leading Bicycle Interval.

TYPICAL APPLICATION

- Leading Bicycle Intervals (LBI) provides bicyclists with a priority headstart across the intersection
- Leading Bicycle Intervals (LBI) are used to reduce right turn and permissive left turn vehicle and bicycle conflicts.
- At locations where increased bicyclist stop compliance is needed.
- Can be paired with Leading Pedestrian Intervals (LPI).

DESIGN FEATURES

- Typically employed with a bike signal, and/or pedestrian signal.
- The through bicycle interval is initiated first, in advance of the concurrent through/right/permissive left turn interval by 3-10 seconds.
- If paired with an LPI, bicycle pushbuttons can be configured to provide additional crossing time when bicyclists arrive at the crossing during the concurrent flashing don't walk interval. The MUTCD requires signage indicating the walk time extension at or adjacent to the push button (R10-32P).
- Actuation may be achieved with either a push button or other passive detection devices.



Bicyclists receive a green bike signal indication in advance of adjacent travel lane



Signal louvers or visibility-limited signal faces reduce the likelihood of motorist in adjacent travel lanes mistaking the bike signal indication with a circular or arrow indication for their travel lane

FURTHER CONSIDERATIONS

- These signal enhancements facilitate safer, more predictable, and conspicuous crossing conditions. The Leading Bicycle Interval provides additional time for bicyclists who may need more time to cross the street such as the elderly, and children.
- Leading Bicycle Intervals are considered a successful application of bike signals as approved under current FHWA Interim Approval for Optional Use of Bicycle Signal Faces (IA-16).
- See Traffic Signal Detection and Actuation for more information on detection and actuation devices.

CRASH REDUCTION

A Leading Bicycle Interval provides a form of temporal separation from other movements and can reduce vehicle-bicycle conflicts by giving bicyclists a headstart, thereby making them more visible, and minimizing exposure times.

CONSTRUCTION COSTS

Bicycle signal heads have an average cost of \$12,800.

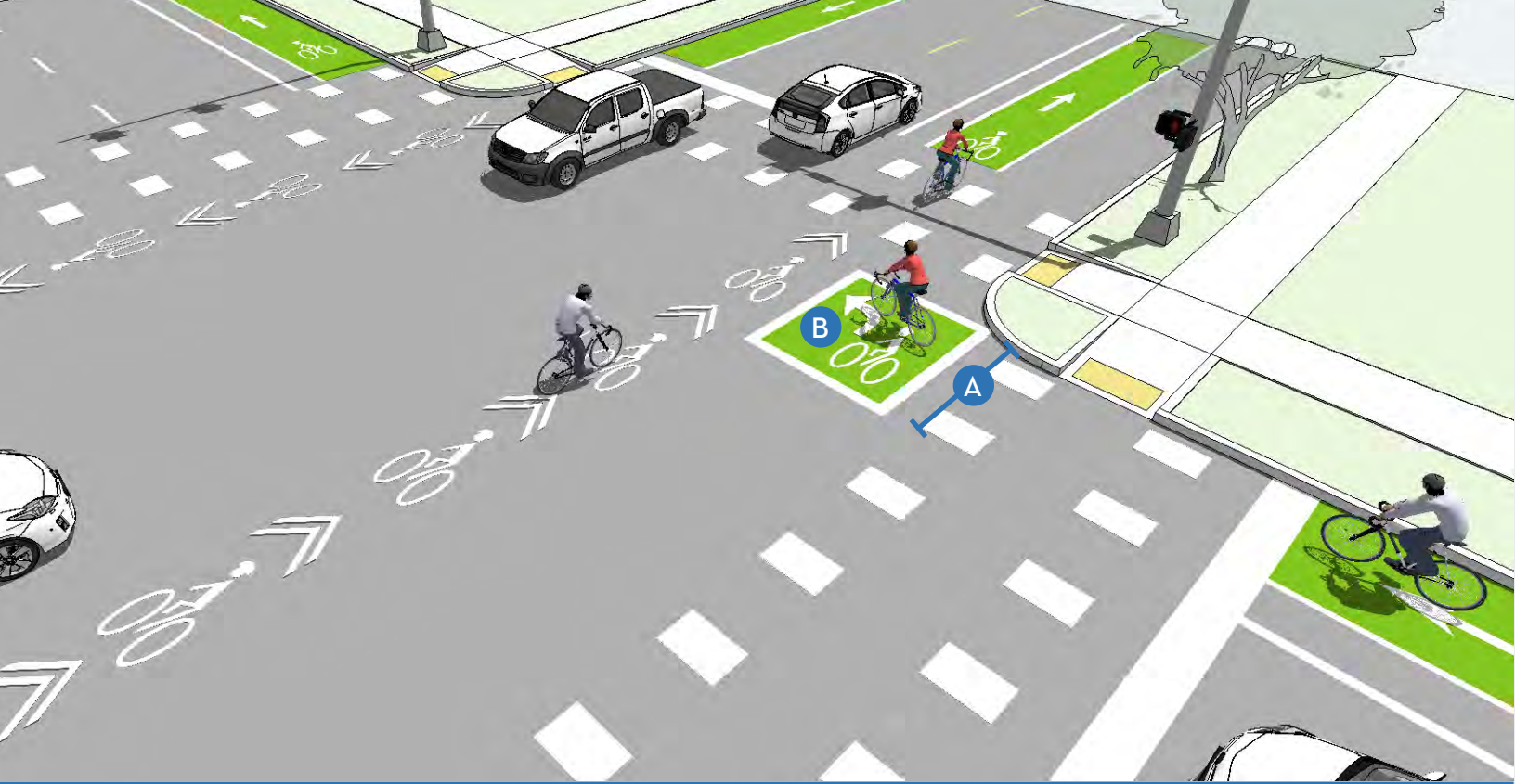

Two-Stage Turn Boxes



Two-stage turn boxes offer bicyclists a safe way to make turns at multi-lane signalized intersections from a physically separated or conventional bike lane. On physically separated bikeways, bicyclists are often unable to merge into traffic to turn due to physical separation, making the provision of two-stage turn boxes critical.

TYPICAL APPLICATION

- Streets with high vehicle speeds and/or traffic volumes.
- At intersections with multi-lane roads with signalized intersections.
- At signalized intersections with a high number of bicyclists making a left turn from a right side facility

DESIGN FEATURES

The two stage turn box shall be placed in a protected area. Typically this is within the shadow of an on-street parking lane or separated bikeway buffer area and should be placed in front of the crosswalk to avoid conflict with pedestrians

- A** 8 foot x 6 foot preferred depth of bicycle storage area (6 foot x 3 foot minimum)
- B** Bicycle stencil and turn arrow pavement markings shall be used to indicate proper bicycle direction and positioning. **(NACTO, 2012)**

Two-stage Turn Box



On separated bikeways, the two-stage turn box can be located in the protected buffer/parking area.

FURTHER CONSIDERATIONS

- Consider providing a “No Turn on Red” (CAMUTCD R10-11) on the cross street to prevent motor vehicles from entering the turn box.
- This design formalizes a maneuver called a “box turn” or “pedestrian style turn.”
- Some two-stage turn box designs are considered experimental by FHWA and is not currently under experiment in California.
- Design guidance for two-stage turns apply to both bike lanes and separated bikeways.
- Two-stage turn boxes reduce conflicts in multiple ways; by keeping bicyclists from queuing in a bike lane or crosswalk and by separating turning bicyclists from through bicyclists.
- Bicyclist capacity of a two-stage turn box is influenced by physical dimension (how many bicyclists it can contain) and signal phasing (how frequently the box clears.)

CRASH REDUCTION

There are no Crash Modification Factors (CMFs) available for this treatment.

CONSTRUCTION COSTS

Costs will vary due to the type of paint used and the size of the two-stage turn box, as well as whether the treatment is added at the same time as other road treatments.

The typical cost for painting a two-stage turn box is \$11.50 per square foot.

Barrier Separation

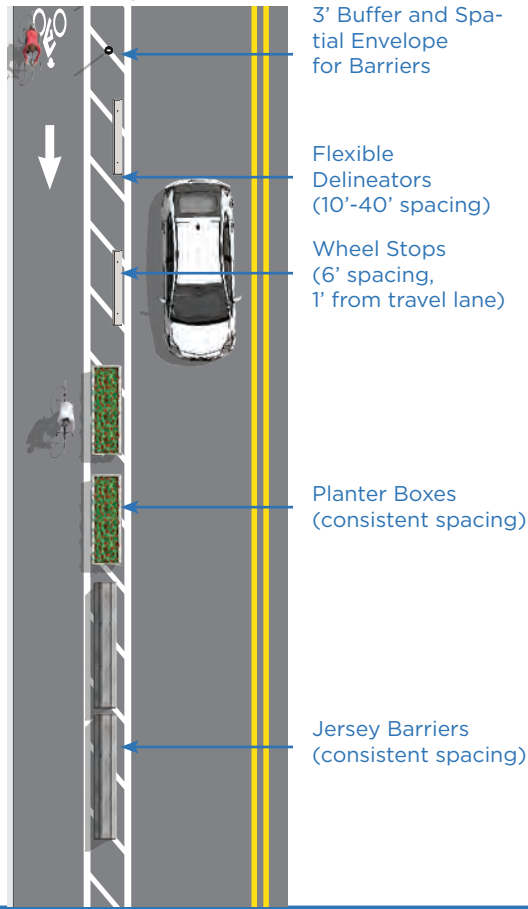

Median Separation



Grade Separation

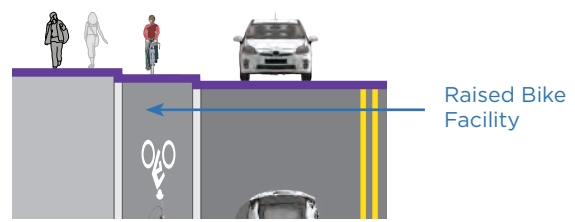

Parking Separation

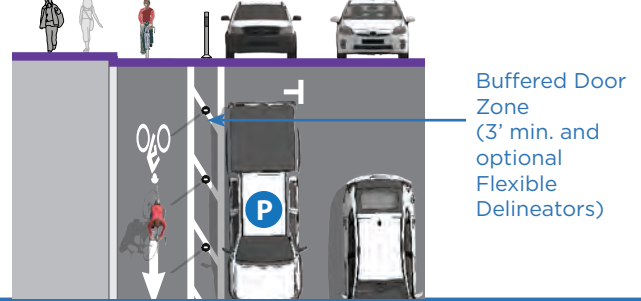

Separated Bikeway Barriers



Separated bikeways may use a variety of vertical elements to physically separate the bikeway from adjacent travel lanes. Barriers may be constructed elements such as curbs, or other elements such as flexible delineator posts.

TYPICAL APPLICATION

Appropriate barriers for retrofit projects:

- Parked Cars
- Flexible delineators
- Bollards
- Planters
- Parking stops

Appropriate barriers for reconstruction projects:

- Curb separation
- Medians
- Landscaped Medians
- Raised separated bikeway with vertical or mountable curb
- Pedestrian Safety Islands

Bikeway Separation Methods



Raised separated bikeways are bicycle facilities that are vertically separated from motor vehicle traffic.



When adjacent to a travel lane, a one-way raised separated bikeway may be configured with a mountable curb. If used, the mountable curb should have a 4:1 slope edge. (NACTO Urban Bikeway Design Guide)

DESIGN FEATURES

- Maximize effective operating space by placing curbs or delineator posts as far from the through bikeway space as practicable.
- Locate vertical elements at least 1 to 2 feet away from the path of travel to maximize usable space for bicyclists.
- When next to parking allow for 3 feet of space in the buffer space to allow for opening doors and passenger unloading.
- The presences of landscaping in medians, planters and safety islands increases comfort for users and enhances the streetscape environment.

FURTHER CONSIDERATIONS

- Separated bikeway buffers and barriers are covered in the CAMUTCD as preferential lane markings (section 3D.01) and channelizing devices (section 3H.01). Curbs may be used as a channeling device, see the section on islands (section 3I.01).

- With new roadway construction a raised separated bikeway can be less expensive to construct than a wide or buffered bicycle lane because of shallower trenching and sub base requirements.
- Parking should be prohibited within 30 feet of the intersection to improve visibility.

CRASH REDUCTION

A before and after study in Montreal of separated bikeways shows that this type of facility can result in a crash reduction of 74% for collisions between bicyclists and vehicles. (CMF ID: 4097) In this study, there was a parking buffer between the bike facility and vehicle travel lanes. Other studies have found a range in crash reductions due to separated bikeways, from 8% (CMF ID: 4094) to 94% (CMF ID: 4101).

CONSTRUCTION COSTS

Separated bikeway costs can vary greatly, depending on the type of material, the scale, and whether it is part of a broader construction project.

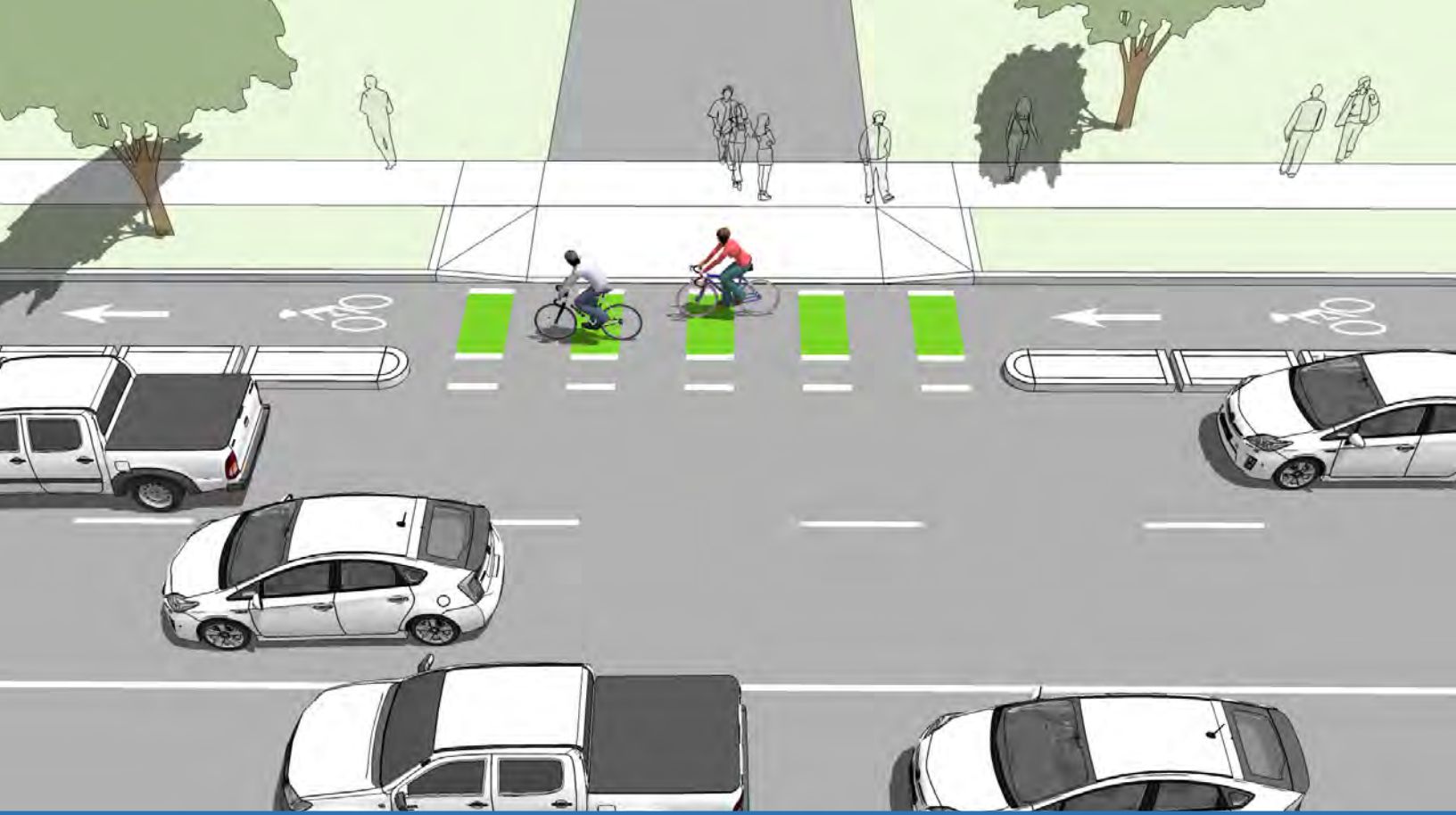

== MID-BLOCK

Separated Bikeways at Driveways (and Minor Streets)

The added separation provided by separated bikeways creates additional considerations at intersections and driveways when compared to conventional bicycle lanes. Special design guidelines are necessary to preserve sightlines and denote potential conflict areas between modes, especially when motorists turning into or out of driveways may not be expecting bicycle travel opposite to the main flow of traffic.

At driveways and crossings of minor streets, bicyclists should not be expected to stop if the major street traffic does not stop.

TYPICAL APPLICATION

- Along streets with separated bikeways where there are intersections and driveways.
- Higher frequency driveways or crossings may require additional treatment such as conflict markings and signs.

DESIGN FEATURES

- Remove parking to allow for the appropriate clear sight distance before driveways or intersections to improve visibility. The desirable no-parking area is at least 30 feet from each side of the crossing.
- Use colored pavement markings and/or shared lane markings through conflict areas at intersections.
- If a raised bike lane is used, the height of the lane should be maintained through the crossing, requiring automobiles to cross over.



Intersection crossing markings can be used at high volume driveway and minor street crossings, as illustrated above.

- Motor vehicle traffic crossing the separated bikeway should be constrained or channelized to make turns at sharp angles to reduce travel speed prior to the crossing.
- Driveway crossings may be configured as raised crossings to slow turning cars and assert physical priority of travelling bicyclists.
- Motor vehicle stop bar on cross-streets and driveways is setback from the intersection to ensure that drivers slow down and scan for pedestrians and bicyclists before turning.

FURTHER CONSIDERATIONS

- Removing obstructions and providing clear sight distance at crossings increases visibility of bicyclists.
- Treatments designed to constrain and slow turning motor vehicle traffic will slow drivers to bicycle-compatible travel speeds prior to crossing the separated bikeway.

CRASH REDUCTION

Raised crossings at driveways and intersections physically indicate priority of path travel over turning or crossing traffic, and reduce conflict risk by 51%.¹

CONSTRUCTION COSTS

The cost for installing high visibility colored crossing markings will depend on the materials selected and implementation approach. Typical costs range from \$1.20/sq. ft. installed for paint to \$14/sq. ft. installed for Thermoplastic. Colored pavement is more expensive than standard asphalt installation, costing 30-50% more than non-colored asphalt.

¹ Schepers et al. Road factors and bicycle-motor vehicle crashes at unsignalized priority intersections. *Accident Analysis & Prevention*. Volume 43, Issue 2, 2011.



Loading and Garbage Access

— MID-BLOCK

Where separated bikeways are adjacent to accessible on-street parking, freight loading zones, or designated garbage pick-up areas, an accessible aisle should be provided to allow for travel from the vehicle to the curb ramp.

TYPICAL APPLICATION

- Streets with on-street parking along the same block face of a separated bikeway.
- Where ADA - accessible spaces are desired, either due to proximity to nearby building entrances, street grades, or other factors.
- Where loading and garbage pick-up zones are desired along the same side of the street as a separated bikeway due to adjacent commercial users such as retail or hotels, and cannot be relocated to adjacent block faces or alleys.

DESIGN FEATURES

- Accessible spaces should be located adjacent to intersections to simplify access to curb ramps.
- Accessible spaces must be at least 20 feet long and 8 feet wide.
- An accessible 5 foot aisle must be provided on street level between on-street parking and the bicycle facility for the full length of the parking space and must connect to a pedestrian access route. The access aisle shall not encroach on the vehicle travel lane. Front and rear aisles should be at least 3 feet to ease parking.



Intersection crossing markings can be used at high volume driveway and minor street crossings, as illustrated above.

- To connect between the sidewalk and parking spaces, a crosswalk across the separated bikeway and curb ramp (6 foot minimum width) must be provided.
- Place a **YIELD HERE TO PEDESTRIANS (MUTCD R1-5)** sign where the separated bikeway crosses the parking access route to clearly establish a right-of-way. Yield line pavement marking may be placed prior to the crosswalk.

CRASH REDUCTION

- Removing obstructions and providing clear sight distance at crossings increases visibility of bicyclists.
- Treatments designed to constrain and slow turning motor vehicle traffic will slow drivers to bicycle-compatible travel speeds prior to crossing the separated bike lane.

CONSTRUCTION COSTS

The cost for installing high visibility colored crossing markings will depend on the materials selected and implementation approach. Typical costs range from \$1.20/sq. ft. installed for paint to \$14/sq. ft. installed for Thermoplastic. Colored pavement is more expensive than standard asphalt installation, costing 30-50% more than non-colored asphalt.

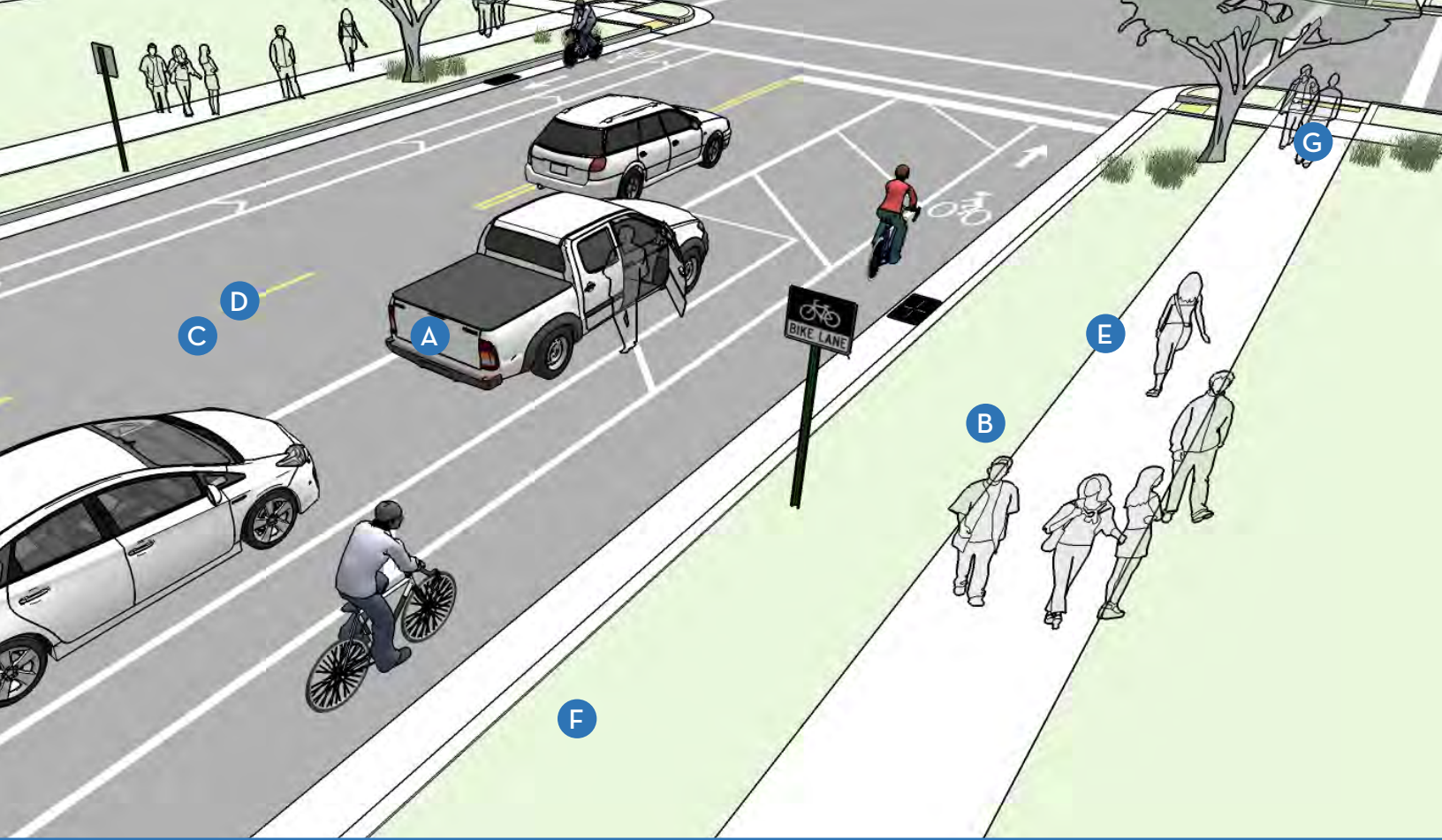

Facility Maintenance



Regular bicycle facility maintenance includes sweeping, maintaining a smooth roadway, ensuring that the gutter-to-pavement transition remains relatively flush, and installing bicycle friendly grates. Pavement overlays are a good opportunity to improve bicycling facilities. The following recommendations provide a menu of options to consider to enhance a maintenance regimen.

A SWEEPING

- Establish a seasonal sweeping schedule that prioritizes roadways with major bicycle routes.
- Sweep walkways and bikeways whenever there is an accumulation of debris on the facility.
- In curbed sections, sweepers should pick up debris; on open shoulders, debris can be swept onto gravel shoulders

B SIGNAGE

- Check regulatory and wayfinding signage along bikeways for signs of vandalism, graffiti, or normal wear.
- Replace signage along the bikeway network as-needed.
- Perform a regularly-scheduled check on the status of the signage with follow-up as necessary.
- Create a Maintenance Management Plan.

C ROADWAY SURFACE

- Maintain a smooth pothole-free surface.
- Ensure that on new roadway construction, the finished surface on bikeways does not vary more than 1/4”.
- Maintain pavement so ridge buildup does not occur at the gutter-to-pavement transition or adjacent to railway crossings.
- Inspect the pavement 2 to 4 months after trenching construction activities are completed to ensure that excessive settlement has not occurred.

D PAVEMENT OVERLAYS

- Extend the overlay over the entire roadway surface to avoid leaving an abrupt edge.
- If the shoulder or bike lane pavement is of good quality, it may be appropriate to end the overlay at the shoulder or bike lane stripe provided no abrupt edge remains.
- Ensure that inlet grates, manhole and valve covers are within 1/4 inch of the finished pavement surface and are made or treated with slip resistant materials.

E DRAINAGE GRATES

- Require all new drainage grates be bicycle-friendly. Grates should have horizontal slats on them so that bicycle tires and assistive devices do not fall through any vertical slats.
- Create a program to inventory all existing drainage grates, and replace hazardous grates as necessary - temporary modifications such as installing rebar horizontally across the grate should not be an acceptable alternative to replacement.

F GUTTER-TO-PAVEMENT TRANSITION

- Ensure that gutter-to-pavement transitions have no more than a 1/4” vertical transition.
- Examine pavement transitions during every roadway project for new construction, maintenance activities, and construction project activities that occur in streets.

G LANDSCAPING

- Ensure that shoulder plants do not hang into or impede passage along bikeways.
- After major damage incidents, remove fallen trees or other debris from bikeways as quickly as possible.

MAINTENANCE MANAGEMENT PLAN

- Provide fire and police departments with map of bikeway system, along with access points to gates/ bollards.
- Enforce speed limits and other rules of the road.
- Enforce all trespassing laws for people attempting to enter adjacent private properties.

RECOMMENDED WALKWAY AND BIKEWAY MAINTENANCE ACTIVITIES

Maintenance Activity	Frequency
Inspections	Seasonal – at beginning and end of Summer
Pavement sweeping/blowing	As needed, with higher frequency in the early Spring and Fall
Pavement sealing	5 - 15 years
Pothole repair	1 week – 1 month after report
Culvert and drainage grate inspection	Before Winter and after major storms
Pavement markings replacement	As needed
Signage replacement	As needed
Shoulder plant trimming (weeds, trees, brambles)	Twice a year; middle of growing season and early Fall
Tree and shrub plantings, trimming	1 – 3 years
Major damage response (washouts, fallen trees, flooding)	As soon as possible