

OBSTRUCTION TO PART 77 SURFACES								
POINT ID	OBJECT PENETRATION (FT)	DESCRIPTION	OBSTRUCTION ELEVATION (FT)	PART 77 ELEVATION (FT)	PART 77 SURFACE	EG ELEVATION (FT)	FAA STUDY ID	PROPOSED DISPOSITION
123	31	BLDG	355	324	TRANSITIONAL	280	N/A	LIGHT
124	19	BLDG	346	327	TRANSITIONAL	278	N/A	LIGHT
128	95	BLDG-TWR	642	547	CONICAL	UNKNOWN	0092_AW009590E	NONE
130	27	BLDG-TWR	630	603	CONICAL	UNKNOWN	2002AWP040520E	NONE
135	209	TOWER	639	430	HORIZONTAL	UNKNOWN	0066_SF00070E	LIGHT
136	14	TOWER	634	620	CONICAL	UNKNOWN	0069_SF002370E	NONE
140	19	BLDG-TWR	533	514	CONICAL	UNKNOWN	N/A	NONE
144	34	TOWER	565	531	CONICAL	UNKNOWN	N/A	NONE
445	5	ANTENNA	607	602	CONICAL	UNKNOWN	N/A	NONE
446	28	BUILDING	574	547	CONICAL	UNKNOWN	N/A	NONE
472	29	CONTROL TOWER	353	323	TRANSITIONAL	280	N/A	REMOVE
476	20	ANTENNA	347	327	TRANSITIONAL	278	N/A	LIGHT
653	5	NAVAID	303	298	TRANSITIONAL	278	N/A	NONE
2000	-87	PRIMARY ROAD	273	360	APPROACH RWY 12	256	N/A	NONE
2001	-48	PRIMARY ROAD	285	333	APPROACH RWY 12	268	N/A	NONE
2002	-117	PRIMARY ROAD	283	400	APPROACH RWY 12	266	N/A	NONE

**NOTES:**

- SURVEY DATA FROM 11/16/2018.
- QUAD MAP SOURCE: USGS FRESNO SOUTH, CA 2015.
- TRAVERSE WAY ELEVATIONS ARE ADJUSTED AS SHOWN:
  - 23' FOR RAILWAYS
  - 17' FOR INTERSTATE HIGHWAYS
  - 15' FOR OTHER PUBLIC ROADS
  - 10' FOR PRIVATE ROADS
- NEGATIVE PENETRATION VALUES INDICATE THE CLEAR DISTANCE FROM THE TOP OF THE OBJECT TO THE PART 77 SURFACE.
- THE CITY OF FRESNO HAS NO HEIGHT RESTRICTIONS ZONING ORDINANCES IN PLACE.

**ABBREVIATIONS:**

- EG EXISTING GROUND
- BLDG BUILDING
- TWR TOWER
- NAVAID NAVIGATIONAL AIDS

SEE SHEET 8 FOR RUNWAY 12-30 CENTERLINE PROFILE

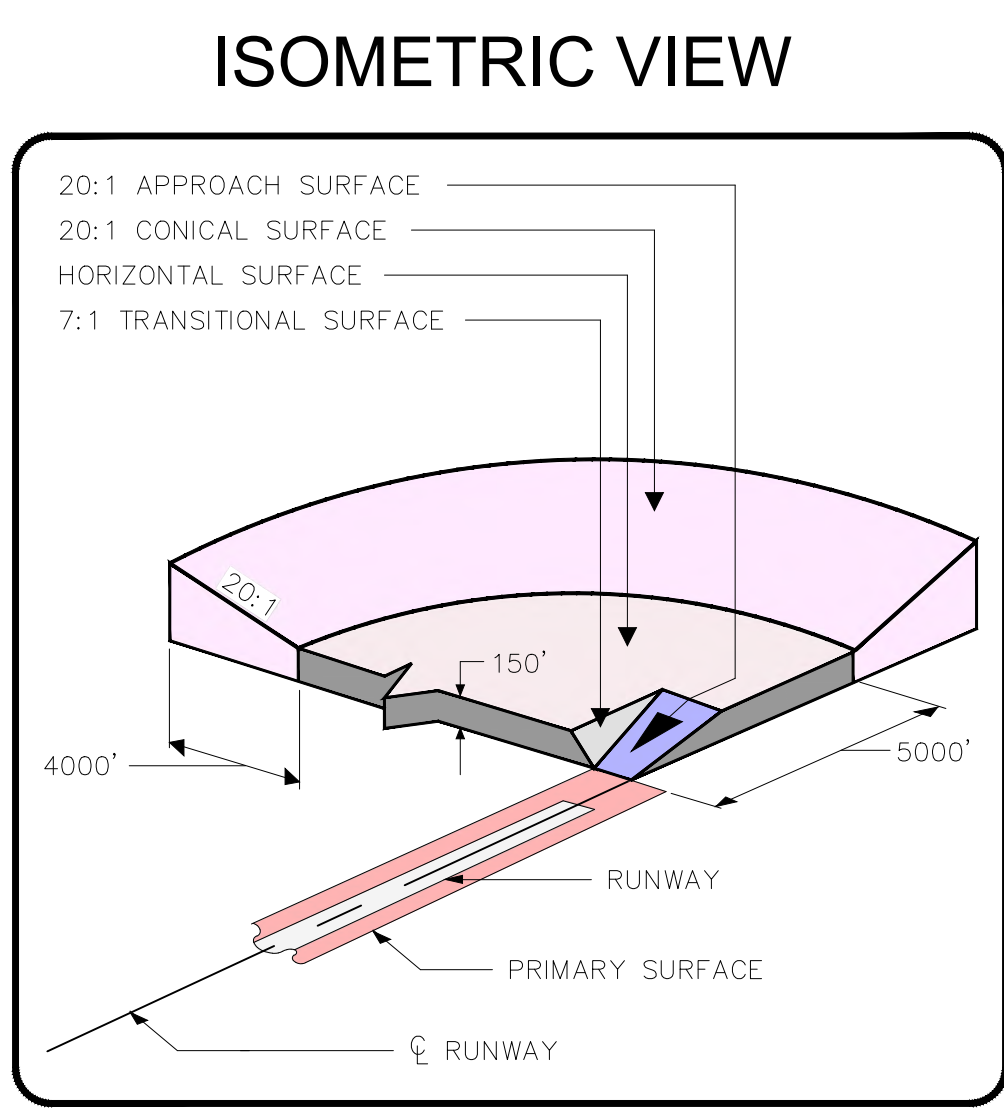

**FRESNO CHANDLER**  
 EXECUTIVE AIRPORT  
 4995 E CLINTON WAY, FRESNO, CA 93727  
 PHONE: 559-621-4500 FAX: 559-251-4825

**AIRPORT LAYOUT PLAN DRAWING SET**

PREPARED BY: **KimleyHorn**  
 11400 COMMERCE PARK DR., SUITE 400, RESTON, VA 20191  
 PHONE: 703-674-1300 FAX: 703-674-1350  
 WWW.KIMLEYHORN.COM

PROJECT NUMBER: 091733014  
 DATE: NOVEMBER 2022  
 DRAWN BY: JC  
 REVIEWED BY: CW  
 APPROVED BY:

No.	REVISIONS	DATE
0	SUBMITTED 2021 DRAFTED ALP SHEET SET	06/29/2021
1	REVISED PER FAA COMMENT LETTER DATED SEPTEMBER 8 <sup>th</sup> , 2022	11/01/2022

SHEET TITLE: **AIRPORT AIRSPACE DRAWING: PLAN VIEW**  
 SHEET NUMBER: **7 OF 15**

THE PREPARATION OF THIS PLAN WAS FINANCED IN PART THROUGH A PLANNING GRANT FROM THE FEDERAL AVIATION ADMINISTRATION AS PROVIDED UNDER SECTION 202 OF THE AIRPORT AND AIRWAY IMPROVEMENT ACT OF 1982. AS AMENDED, THE CONTRACTOR DOES NOT WARRANT OR REPRESENT THE ORIGINAL VIEW OR COPY OF THE PLAN. ACCEPTANCE OF THIS PLAN BY THE FAA DOES NOT IN ANY WAY CONSTITUTE A COMMITMENT ON THE PART OF THE UNITED STATES TO PARTICIPATE IN AND DEVELOPMENT DEPICTED THEREIN NOR DOES IT INDICATE THAT THE PROPOSED DEVELOPMENT IS ENVIRONMENTALLY ACCEPTABLE IN ACCORDANCE WITH APPROPRIATE PUBLIC LAWS.